



ALBION DOCKSIDE WORKS, HANOVER PLACE,
BRISTOL, BS1 6UT, ENGLAND.

TELEPHONE: 0117 927 9204 FACSIMILE: 0117 929 8193
EMAIL: enquiries@seetru.com WEB: www.seetru.com



DESIGN AND MANUFACTURE OF VALVES AND CONTENTS GAUGES.
GENERAL SAFETY VALVE RECONDITIONING SERVICES.

MINI GAUGE G27

Issue: 3
Date: 12.10.10

General Description

The Seetru Mini Gauge consists of a transparent sight tube, protected against breakage by a transparent polycarbonate guard tube or Stainless Steel with viewing slots.

The sight tube is sealed into collars at both ends which in turn are fixed and sealed to the tank by connection nipples.

Installation Instructions

Tank connection thread of 1/4" BSP.PL. is required [standard Mini Gauge connection]. Ensure good surface for flat face seal.

1. The gauge should not be fitted to tank bosses whilst welding bosses to tank, to avoid heat soak damage to seals.
2. After welding, check face and bore of tank boss [or tank face if bosses have not been used] is free of damage and weld splatter. Ensure correct alignment and squareness of top and bottom tank connection to avoid undue strain on gauge.
3. Fit gauge assembly up to tank, ensure seals are in position on collar, screw nipples (item 9) into tank to seal gauge to tank. Tightening torque of 12 – 16Nm MAX.
4. Gauge may be adjusted by +/- 2mm on nominal centre distance by slacking off gland nuts and sliding the collars on the sight tube, retighten gland nuts after adjustment.

The gauge is now ready for service, check for leaks.

Important

Nominal centre distance must not be exceeded by 1.6mm as this could affect the gauge sealing and re-assembly of the gauge, as per maintenance paragraph, will be necessary.

Operation Faults Table

FAULT	PROBABLE CAUSE	RECTIFICATION
Gauge not filling	Empty tank	Fill tank
	Obstruction in gauge	Clear
Broken sight tube	Mis-use	Renew
	Mis-alignment	Renew, check face flat
Leaks from collar seal	Loose retaining nut	Tighten
	Damaged 'O' ring	Renew
Sight tube gland leaking	Loose gland nut	Tighten
	Damaged 'O' ring	Renew
Leaking from tank boss	Nipple loose	Tighten
	Sealing washer damaged	Renew



ALBION DOCKSIDE WORKS, HANOVER PLACE,
BRISTOL, BS1 6UT, ENGLAND.

TELEPHONE: 0117 927 9204 FACSIMILE: 0117 929 8193
EMAIL: enquiries@seetru.com WEB: www.seetru.com



DESIGN AND MANUFACTURE OF VALVES AND CONTENTS GAUGES.
GENERAL SAFETY VALVE RECONDITIONING SERVICES.

MINI GAUGE G27

MAINTENANCE

Before undertaking any maintenance work on gauge, ensure discharge of gauge or tank content will not create a hazard to personnel. Particular attention being given to hazardous fluids, system temperature and pressure.

TO REPLACE SIGHT TUBE, CLEAN GAUGE OR REPLACE SEALS

1. Drain tank.
2. Unscrew top and bottom nipples (9) remove gauge assembly from tank.
3. Remove nipples from collar (8).
4. Check and renew seals (10) if required.
5. Unscrew top gland nut (4) from gauge collar (8)
6. Remove top gauge collar (8) from tubes by pulling.
7. Remove guard tube (2) by sliding off sight tube.
8. Unscrew lower gland nut (4) from lower gauge collar (8).
9. Remove sight tube (1).
10. Clean or renew sight tube, inspect all bushes and seals (5, 6 & 7) renew if required.
11. Check internal passages of collar and nipples are clear of obstructions.
12. Refit lower gland nut, bushes and seals to sight tube.
13. Screw lower gland nut to lower collar.
14. Refit guard tube.
15. Refit upper gland nut, bushes and seals to sight tube.
16. Screw upper gland nut to upper collar.
17. Gauge is now ready for refitting to tank.

DESIGN AND MANUFACTURE OF VALVES AND CONTENTS GAUGES.
GENERAL SAFETY VALVE RECONDITIONING SERVICES.

MINI GAUGE G27

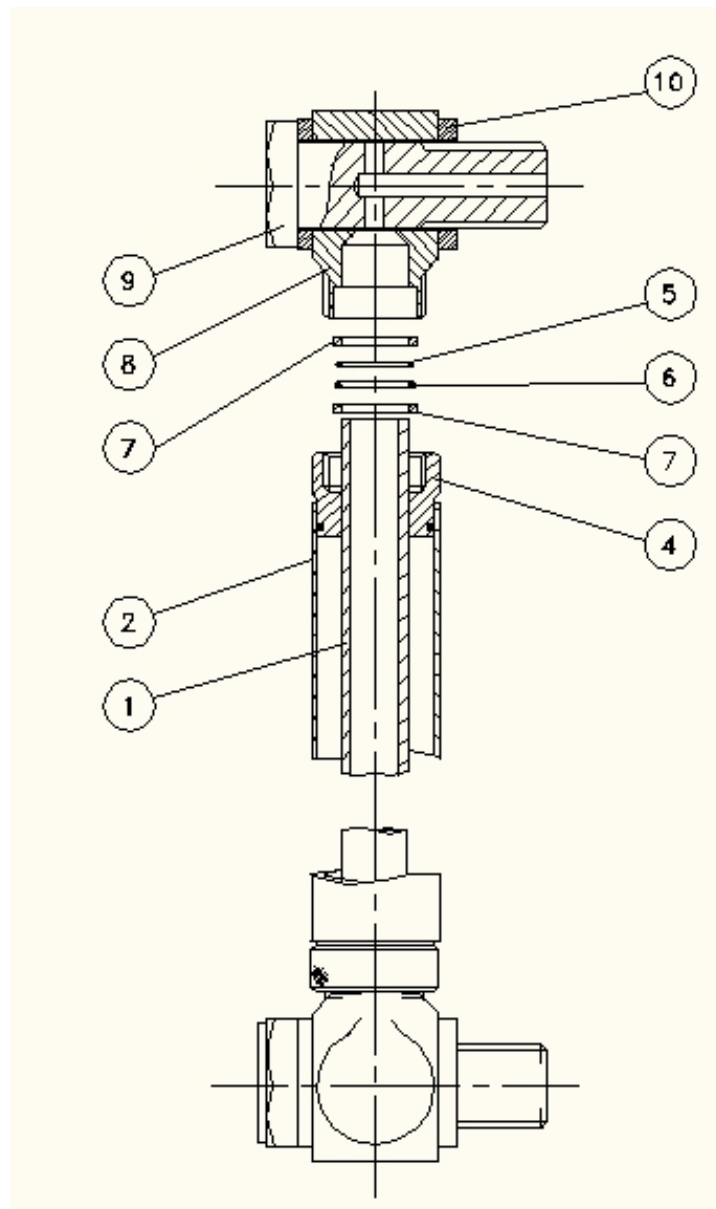

Assemble as follows:

Gland nut (4) to be placed over sight tube (1), then one ferrule (7), large O'ring (6) SXX01433, small O'ring (5) SXX01333, then the second ferrule (7), which should then be pushed into the collar (8) and the gland nut (4) to be screwed onto the collar (8) and tightened to 12Nm.