



## Installation, operating and maintenance Instructions for Seeflex Gauge

Seetru Limited  
Albion Dockside Works  
Bristol, BS1 6UT, UK

Phone +44 (0) 117 927 9204  
Fax +44 (0) 117 929 8193  
Email enquiries@seetru.com

**Issue: 8**  
**Date: 07-10-2022**

### **Type G31**

#### **General information**

The Seetru Marine Gauge - Seeflex model has been developed to comply with the requirements of SOLAS chapter 11-2 regulation 15. The gauge has been reviewed and in a suitable construction is accepted by marine classification authorities throughout the world.

The Seetru Seeflex Gauge is a direct reading liquid level gauge, which is mounted on the outside face of a tank. It consists of one or more sections of Reflex glass and one or more valves. The Reflex glass enables clear liquids to be easily read. The valve(s) control the flow of liquid from the tank to the gauge. To read the tank level, the valve(s) must be opened; this allows the contents of the tank to transfer to the gauge. When the level has stabilised and the reading taken, the valve(s) are closed, this isolates the tank contents from the gauge.

Seetru push-button operated, self-closing isolating valves have been used on marine installations for many years. The Seeflex Gauge incorporates this well-proven design, which provides full safety in preventing liquid loss from the tank. The tank will remain sealed by the self-closing valve even if the gauge column is totally destroyed. This is achieved by placing the sealing system at the back of the valve, which is protected by the tank boss inside the tank.

**Note: Except where otherwise specified the term 'valve', when used in this document, refers to a push button, self-closing valve.**

A tank boss is supplied with each isolating valve. The standard boss is suitable for welding to the tank, but bosses for non-weld installations are available, see **Figure 17**, for detailed information.

This equipment may be fitted with a hydraulic actuation system, which may be required by certain classification authorities.

#### **Technical specification.**

Maximum working pressure = 2.67 bar

Maximum working temperature with hydraulic actuation = 80 °C

Maximum working temperature without hydraulic actuation = 88 °C

**Note: These are the maximum working limitations of the gauge. Classification authorities or operating conditions may require lower working limits.**



## Gauge Type Options.

### Closed Circuit Gauges.

These gauges are mounted such that both ends of the gauge penetrate the tank wall. In this way the gauge forms a closed link or circuit with the tank contents.

#### Valve at bottom, Valve at top

(see Figure 1)

This allows the column to be removed at any time. The tank connections are able to seal the tank even when the level of liquid is above the gauge top fitting. This is the most common configuration.

Note: Both valves must be opened to obtain true reading of liquid level in tank.

#### Valve at bottom, Valveless return at top

(see Figure 2)

The top fitting does not seal the tank from the gauge but provides a continuously open link. The top fitting must always be above the maximum filling level of the tank. Valveless top return configuration must not be used where the tank is pressurised.

#### Valve at bottom, Pipe union to tank at top

(see Figure 3)

The top fitting is connected to the tank top. This is useful when the tank is pressurised i.e. the small amount of gas above the liquid in the gauge is pressurised to the same level as the gas above the liquid in the tank. The column can only be removed when level of liquid in the tank is below the top fitting and the pressure has been released.

### Open Circuit Gauges

These gauges are mounted such that only the bottom fitting, which must be a push button valve, penetrates the tank wall.

#### Valve at bottom, Pipe union to tank vent at top

(see Figure 3)

Similar configuration to Valve bottom, pipe union to tank top, except the top fitting is connected to the tank vent.

#### Valve at bottom, Auto safety vent valve at top (ASV)

(see Figure 4)

The top fitting is connected to atmosphere through an ASV Valve. This unit allows air to enter or exit the top of the gauge but does not allow liquid to leave the gauge.

### Hydraulic Actuation

(see Figures 5 & 6)

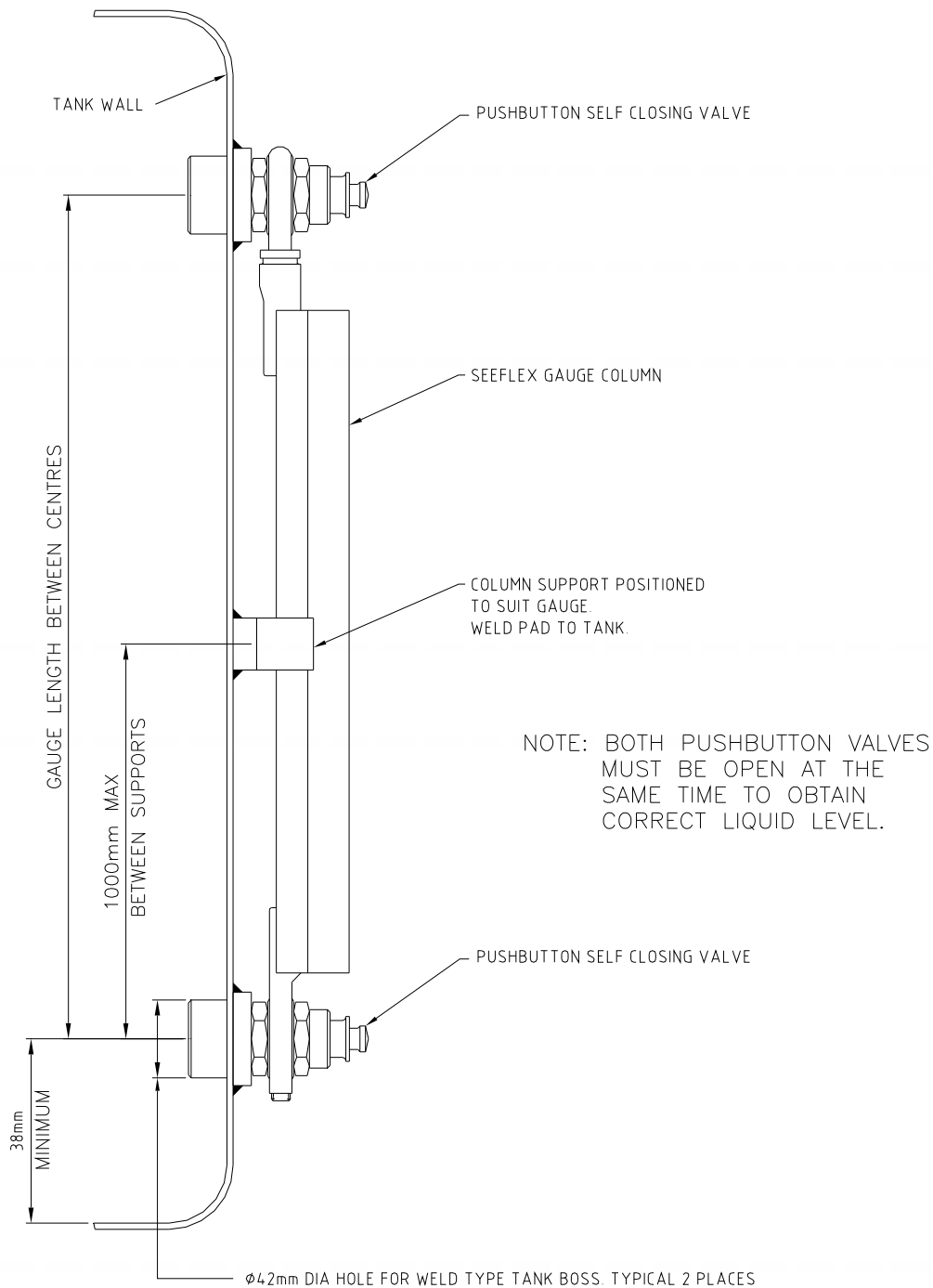
Long gauges with valves top and bottom may be fitted with hydraulic actuation so that both valves are operated simultaneously from a single location. The hydraulic actuation system may be fitted to existing gauges. For further information on the hydraulic systems see the section:

# Installation, operating and maintenance Instructions for Seeflex Gauge

**Seetru Limited**  
Albion Dockside Works  
Bristol, BS1 6UT, UK

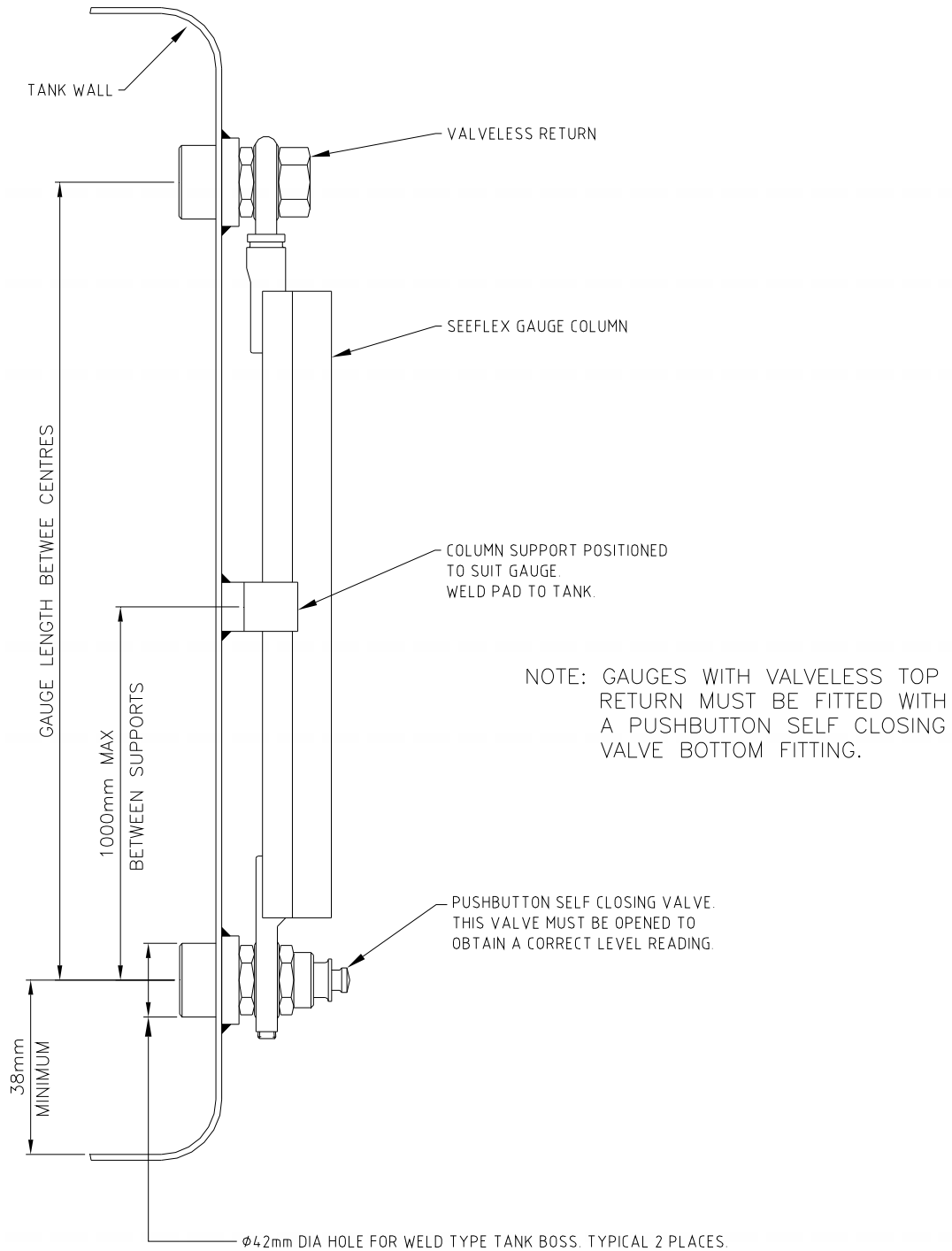
Phone +44 (0) 117 927 9204  
Fax +44 (0) 117 929 8193  
Email [enquiries@seetru.com](mailto:enquiries@seetru.com)

Figure 1.  
Valves fitted top and bottom of the Gauge.



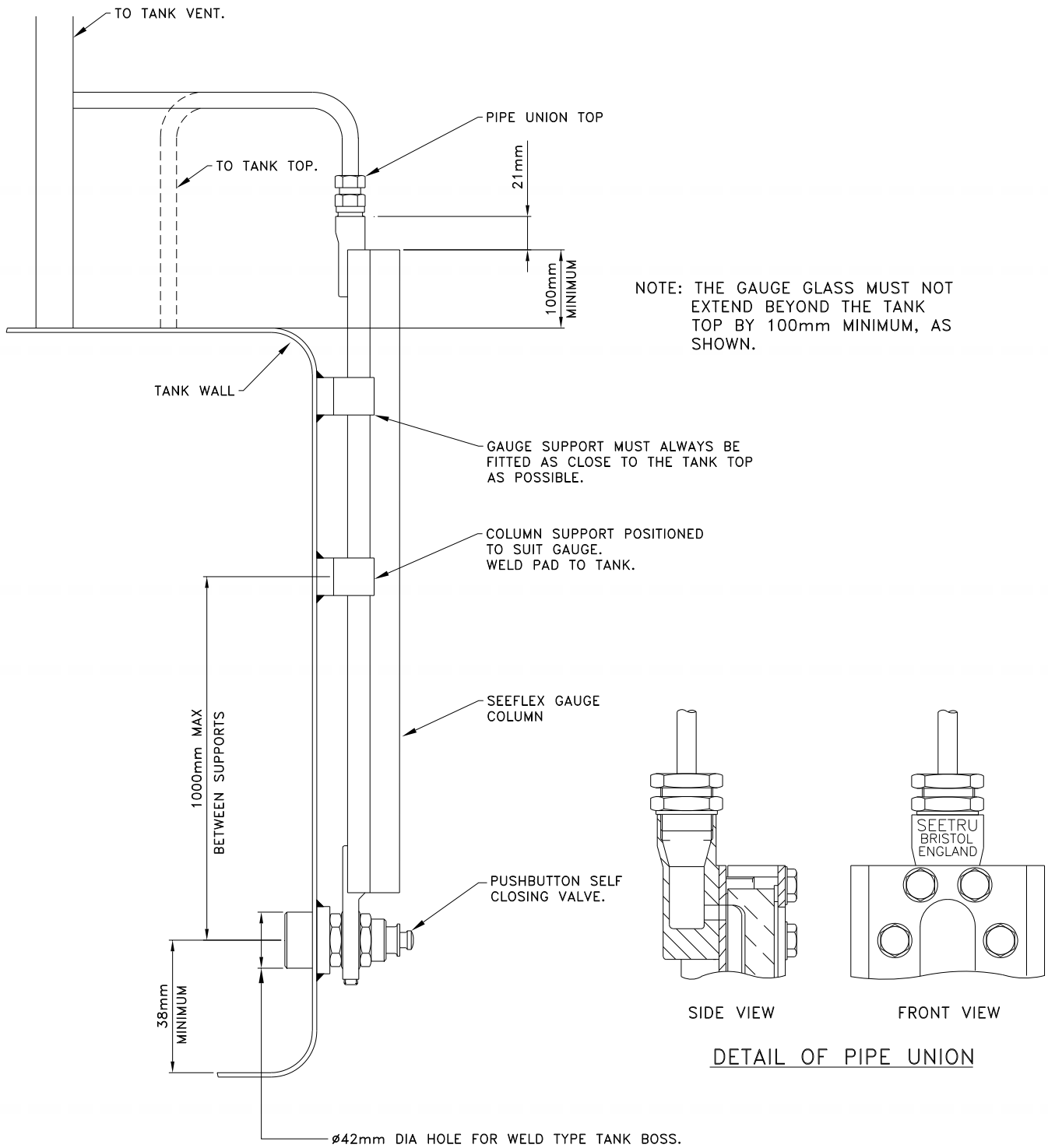
Note: For Column Support dimensions, see **Figure 16**

Figure 2.  
Valves fitted at bottom, Valveless top return.



Note: For Column Support dimensions, see **Figure 16**

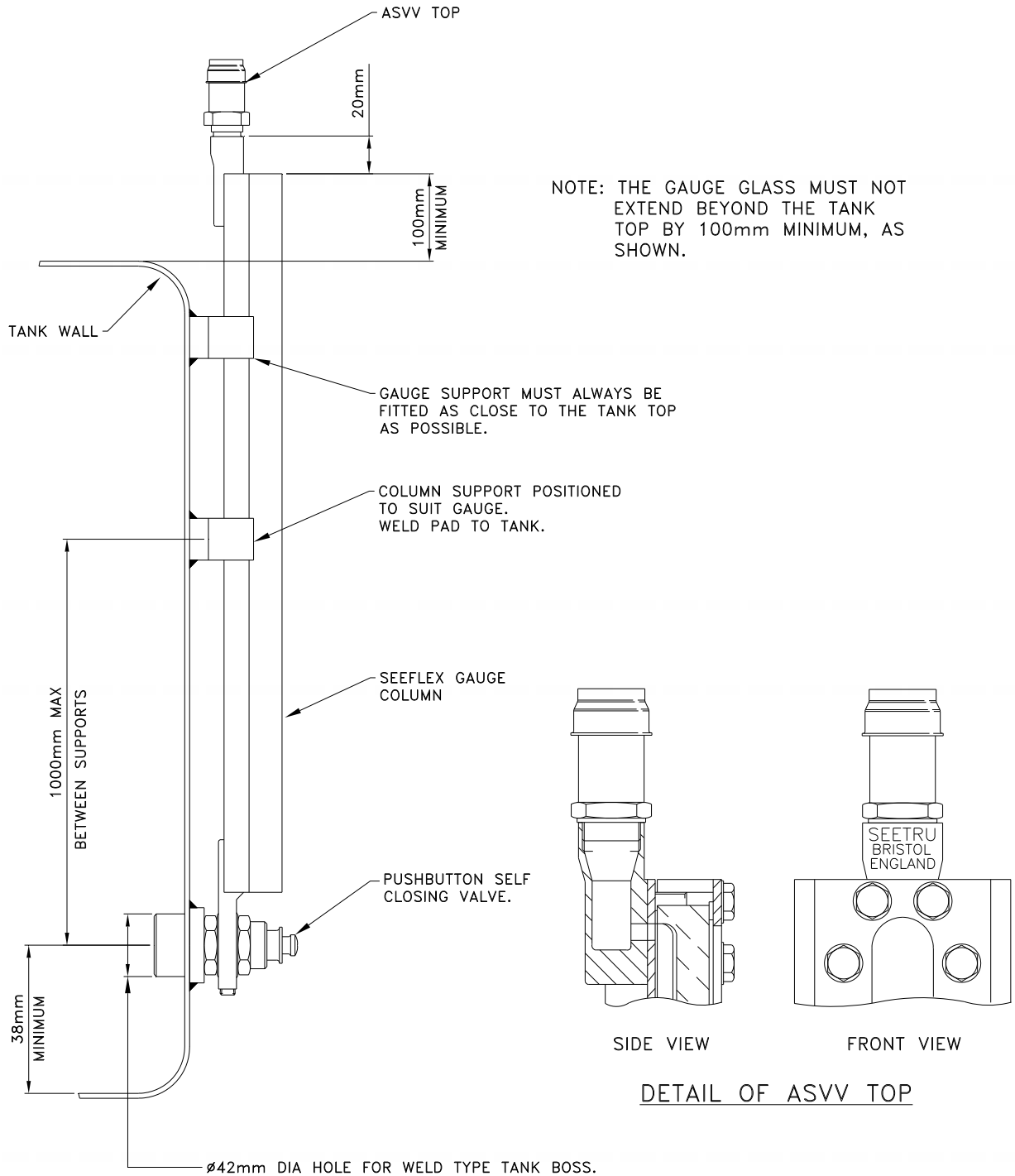
Figure 3.  
**Valve at bottom, Pipe Union to tank top / tank vent.**



Note: For Column Support dimensions, see **Figure 16**

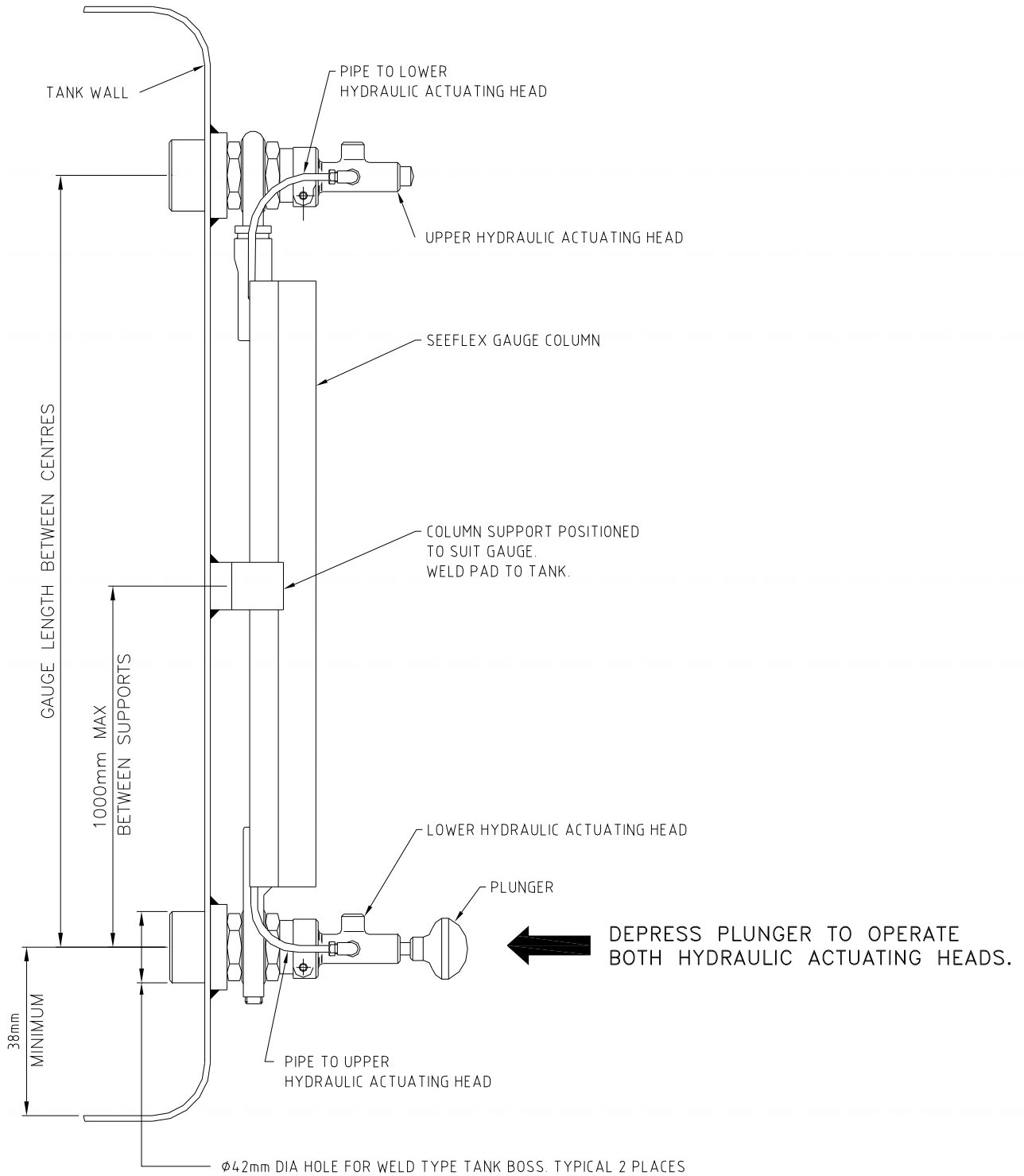
# Installation, operating and maintenance Instructions for Seeflex Gauge

Figure 4  
Valve at bottom, Auto Safety Vent Valve at top.



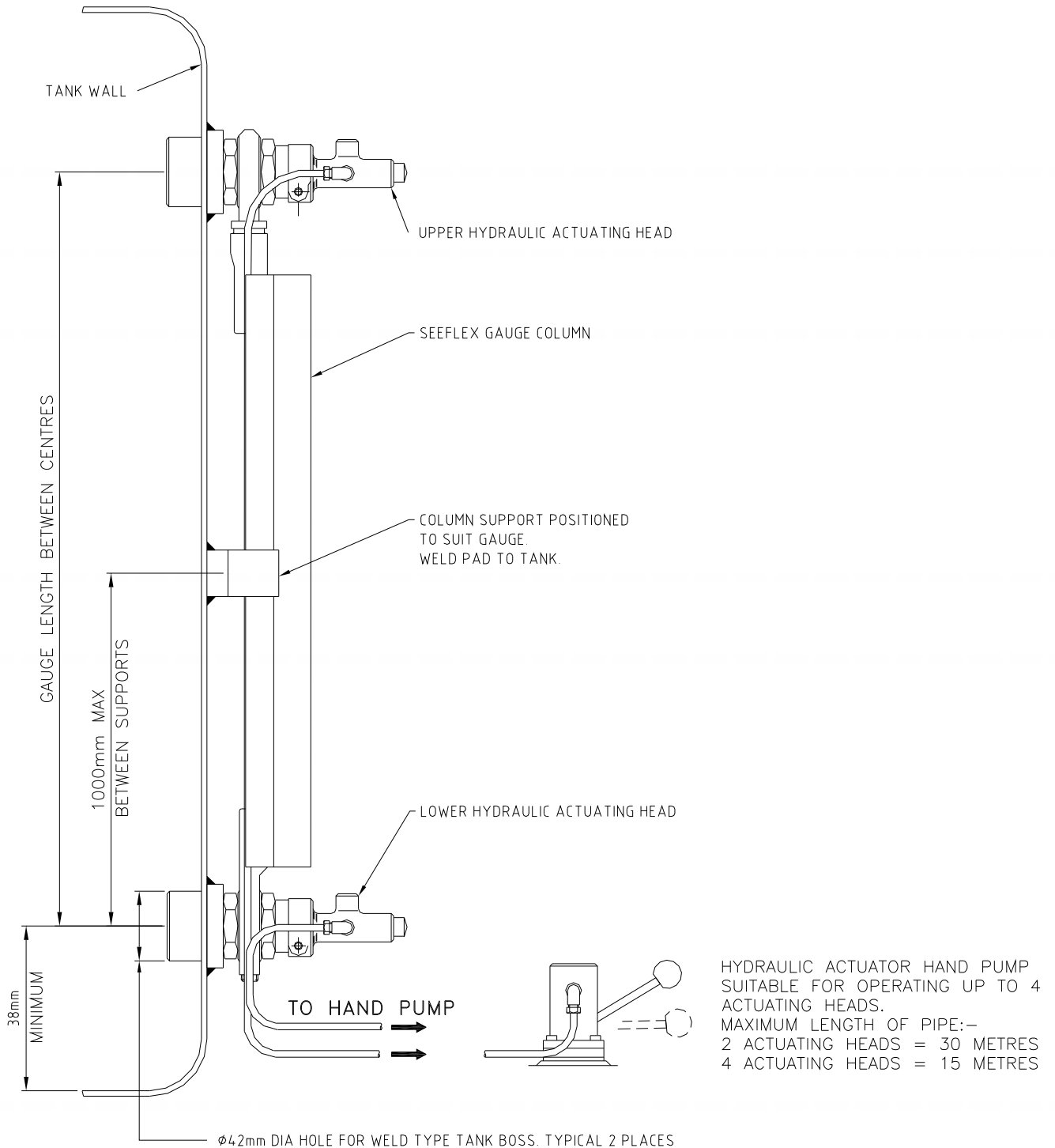
Note: For Column Support dimensions, see **Figure 16**

Figure 5.  
**Hydraulic Actuation single gauge.**



Note: For Column Support dimensions, see **Figure 16**

Figure 6.  
**Hydraulic Actuation multiple gauge.**



Note: For Column Support dimensions, see **Figure 16**



## **INSTALLATION INSTRUCTIONS**

### **READ ALL INSTALLATION INSTRUCTIONS BEFORE COMMENCING WORK.**

#### **Important note**

The Seeflex liquid level gauge is designed to be securely fitted to the side of a tank. Before the gauge is mounted on the tank it is fragile and must be handled with care. Do not pick the gauge up from one end, when lifting, support the gauge along its entire length. If working on a bench the gauge must be rigidly supported at least every 1000mm.

Gauges should be stored preferably between 5°C & 25°C and at a relative humidity of less than 75%. Very moist or very dry conditions should be avoided.

#### **Tank Preparation**

- Choose a position on the tank, which is flat and unobstructed vertically to mount the gauge.
- Carefully unpack the gauge and check the valve centre distance (if applicable)
- For gauges with a valve at the bottom and either a valve or valveless fitting at the top, mark out two holes on the tank wall at the same centre distance as the gauge centres. If your gauge has a valve at the bottom only, mark the bottom hole only. These holes will locate the gauge and so must be positioned vertically.
- The bottom hole must be above any known or suspected sludge levels.
- Drill a 42mm diameter hole at each marked position.
- Remove from the gauge valves from the tank bosses supplied.
- Insert the bosses into the holes in the tank and weld into position.
- Check that the boss bores are free of weld spatter. These bores may be protected with silicon grease prior to welding.
- Use Arosta 316L-150 (or equivalent) welding rods for mild steel tanks.
- All welding must be to the satisfaction of classification surveyor.

#### **Gauge (see Figure 10 on page 13 and Figure 11 on page 14)**

- Remove the isolation valves from the gauge by unscrewing the retaining nuts. Take care not to damage the collar seals.
- Screw the isolation valves into the tank bosses after first checking that the bosses are cold.
- Support the gauge vertically; slide the gauge collars over the isolation valves (now protruding from the tank).
- If the gauge valve center distance is in excess of 1000mm intermediate supports are supplied. These require packing plates (supplied) to be welded to the tank.
- If present, equally space the support pads along the gauge at not more than 1000mm centres. Tack weld the pads to the tank.
- Loosen the support brackets and remove the gauge from the tank.
- Complete the welding of the support pads.
- Mount the gauge on the tank and tighten the support brackets. Check collar inner 'O' rings are in position.
- Fit the outside 'O' rings to the top and bottom isolation valves, screw on the retaining nuts and tighten.
- It is possible to adjust the gauge isolation valve centre distance on closed circuit gauges by plus or minus 5mm by sliding the top gauge collar in or out.
- If the top gauge collar is removed completely **DO NOT PUSH IT BACK THROUGH THE GLAND**, this would damage the internal seals.

#### **If the gauge collar is pulled out, follow this procedure;**

- Remove the gland nut; P.T.F.E. spacer, and 'O' ring from the gauge collar housing. Assemble these components onto the gauge collar stem in this sequence: first, metal gland nut; second, white P.T.F.E. spacer; third, 'O' ring. Then fit this assembly into the gauge collar housing. When the collar is in the correct position screw the gland nut in hand tight.

### Gauges Over 3.8 Meters in Length

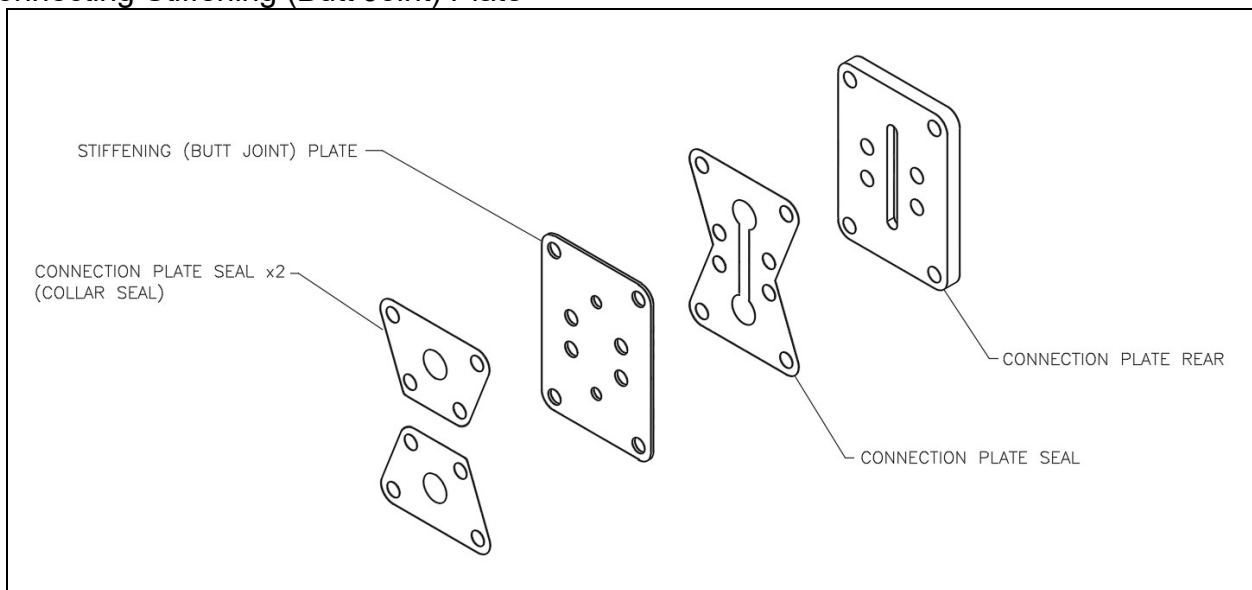
- Gauges over 3.8 meters are supplied split for packing. The gauge column sections must be joined together end on end as installation progresses. This is easier done if the lower portion of the gauge is attached to the tank.
- The connecting plate (rear), stiffening (Butt Joint) plate and connection plate gasket (x2 collar) seals, assembled as shown in **Figure 7**, will already be fastened to one gauge section, this should not be disturbed.
- Remove the nuts and bolts from the gauge section, which will join to the connecting plate. Fit the top gauge section in position on lower gauge section; ensure that the gaskets are correctly aligned. Refit the nuts and bolts and tighten to 3Nm (26 lbs inches)

Continue the installation as though a one-piece gauge.

### WARNING

Connection plates are designed to join sections vertically and will not support the gauge sections in a horizontal position.

Figure 7.  
Connecting Stiffening (Butt Joint) Plate



### COMMISSIONING

Fill the tank. Depress the push button in the centre of the isolation valves and the gauge will fill. Check the tank boss and collar seals for leaks.

**Note:** Both valves must be opened to obtain true level reading.

The push button isolation valve completely isolates the tank contents, therefore if the valve collar seals leak, the collar securing nut may be removed and the seals inspected. Removing the gauge column will not permit the tank contents to leak, however any fluid in the gauge will be released. On gauges with valveless top return the column or top seal can only be removed if liquid level is below the top fitting.

If the tank boss seal leaks, the push button isolating valve must be removed. The tank must be drained to a level below the leaking valve before attempting this repair.

## **MAINTENANCE**

Figures in ( ) refer to parts list on Figure 10. See also Figure 11.

### **A To remove and replace the gauge column from the tank**

Note: Removing the gauge column from the tank will not cause the contents of the tank to be lost; provided that the push button valves are closed i.e. their buttons are **NOT** depressed. Removing the gauge column from the tank will cause any fluid in the gauge to drain out.

- Remove the valve retaining nuts (3)
- Unscrew the intermediate support clamping bolts. Lift the gauge column away from the tank.
- Take care not to drop the gauge column onto the bottom valve unit.
- Remove and discard the collar 'O' ring seals (12).
- Reverse the procedure to replace the gauge column, using new nuts for the intermediate clamping bolts and new 'O' rings for the collar seal.

### **B To replace a reflex glass unit or reflex glass unit gasket**

Any section of the Seeflex gauge column assembly can be dismantled and reassembled in position against the tank. Care must be taken when doing so as any liquid contents within or above the section being maintained will be released. Alternatively, the column may be removed from the tank by reference to maintenance paragraph **A** above.

#### **1. DISMANTLE PROCEDURE**

Remove M6 nuts and bolts from the section to be dismantled.  
Remove front bezel.  
Remove cushion gasket  
Remove reflex glass  
Remove reflex seal

#### **2. CLEANING**

Use clean cloth and mild detergent.  
Clean glass.  
Clean exposed back channel to ensure any deposited trace of gasket is removed. It is important not to damage the back channel surface as even the smallest abrasion may cause the column to leak.  
If the connection plate or collar units are dismantled, clean the gasket faces ensuring the sealing face is not damaged.

#### **3. REPLACEMENT PARTS**

Always use new reflex seals.  
Always use new connection plate gaskets (if dismantled).  
Always use new collar gaskets (if dismantled).  
Always use new M6 'nyloc' nuts.  
Cushion gasket can be reused if in good condition.  
Glass can be reused if in good condition.  
Bolts can be reused if in good condition.

#### **4. RE-ASSEMBLY**

Reassemble in reverse order and as shown in **Figure 11**.

## 5. TORQUE TIGHTENING SEQUENCE

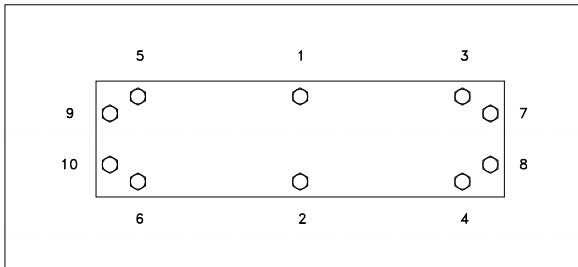
### No.6 Section

Progressively torque bolts to 3 Nm in sequence shown below.

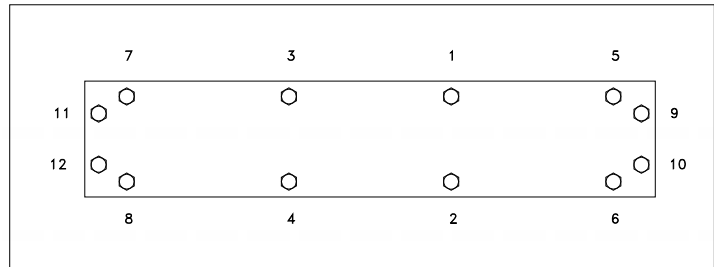
### No. 9 Section

Progressively torque bolts to 3 Nm in sequence shown below.

**Figure 8**



**Figure 9**



After complete re-assembly and before allowing liquid into gauge, check all bolts are tight to 3 Nm in the sequence shown.

### **C To replace push rod 'O' ring (11)**

**Important:** The liquid level in the tank must be below the push button valve before the push rod is removed.

Removing the push rod will allow the tank contents to drain out.

- Remove retaining clip (9)
- Remove push rod (4)
- Inspect or replace 'O' ring (11)
- Check for obstructions
- Reassemble in reverse order.

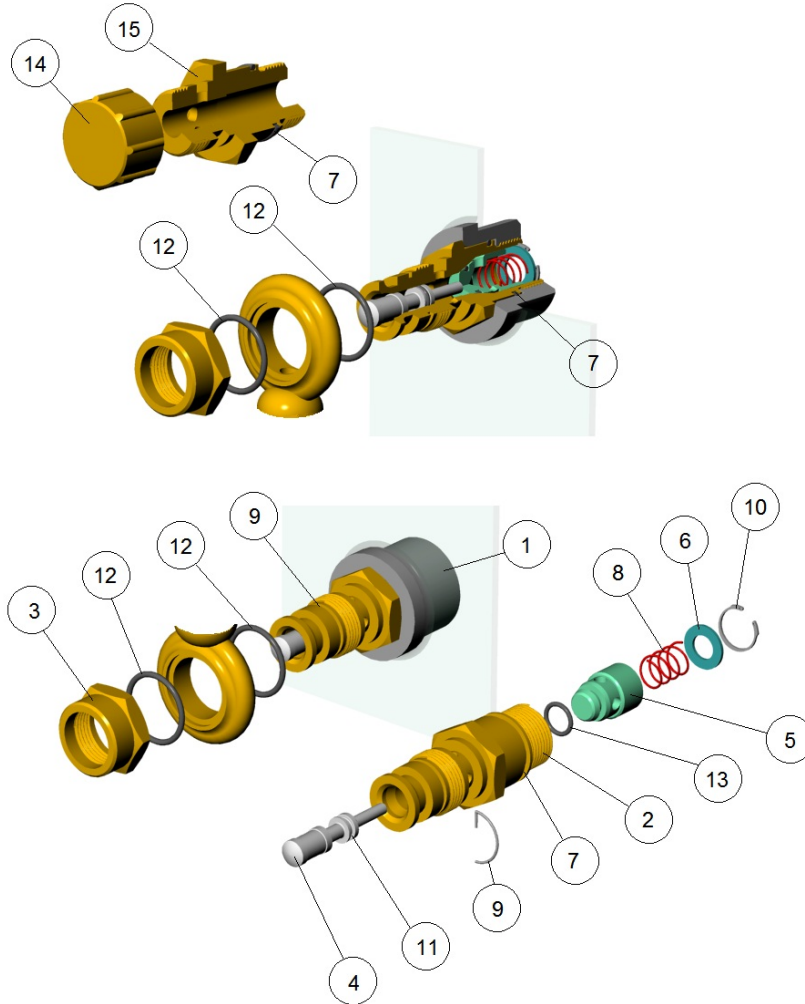
### **D To inspect or replace tank boss 'O' ring (7)**

- Drain tank to below level of connection
- Remove gauge from tank as described in maintenance paragraph **A**
- Unscrew and remove valve unit from tank boss
- Inspect 'O' ring (7) replace if necessary
- Check bore in tank boss is smooth and clean
- Reassemble in reverse order.

### **E To inspect or replace shut off valve 'O' ring seal (13) or shut off valve spring (8)**

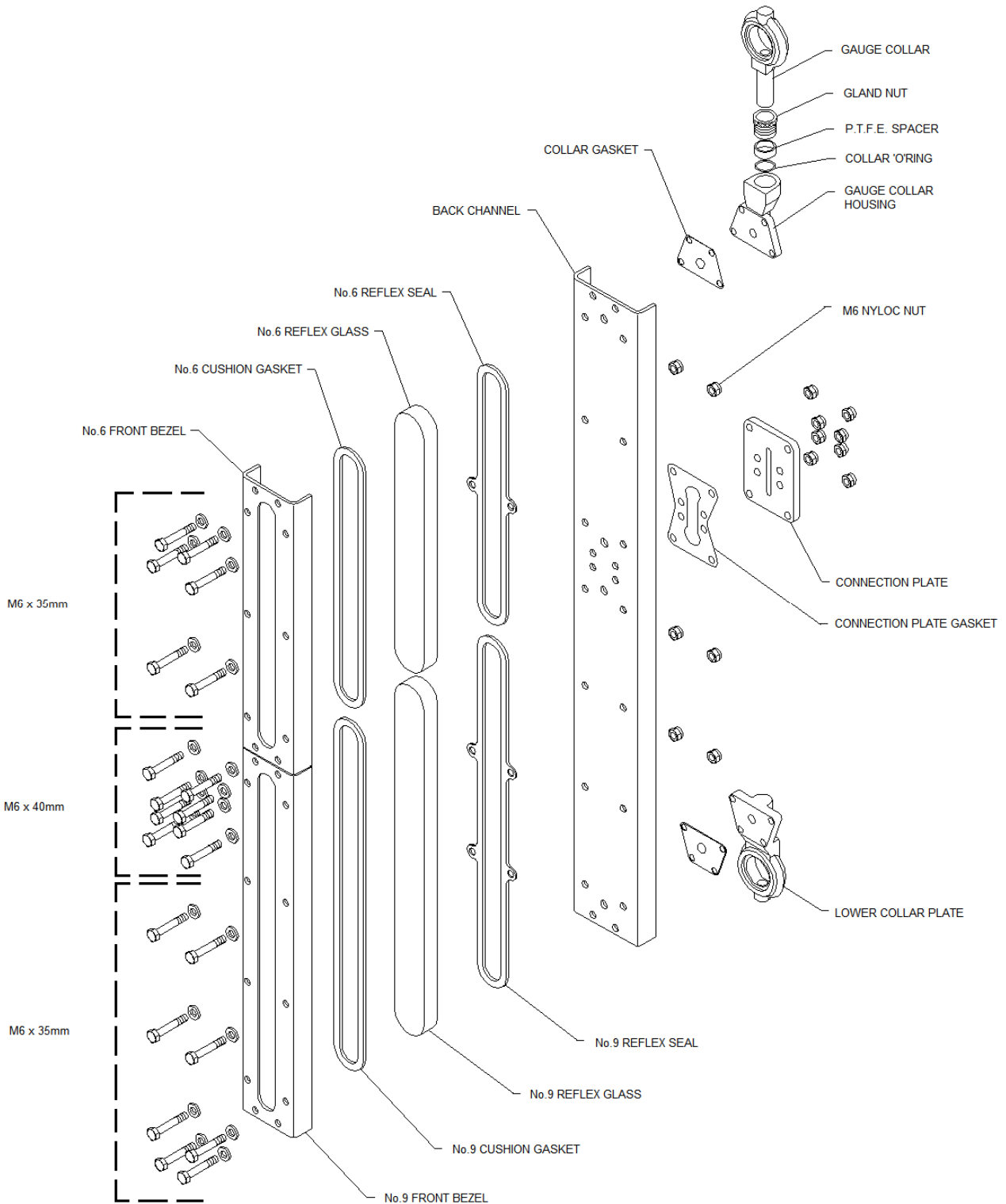
- Drain tank to below level of connection
- Remove gauge from tank as described in maintenance paragraph **A**
- Unscrew and remove valve unit from tank boss (1)
- Remove circlip (10) from rear of unit
- Remove spacer (6)
- Inspect or replace spring (8)
- Remove shut of valve (5)
- Inspect or replace 'O' ring (13)
- Check internal passage of body (2) to be free of obstructions
- Inspect and wipe clean bore and valve seating
- Check bore in tank boss (1) to be smooth and clean
- Inspect 'O' ring (7) replace if necessary
- Reassemble in reverse order.

**Figure 10.**  
Valve Parts List & Diagram



ITEM No.	DESCRIPTION	ITEM No.	DESCRIPTION
1	TANK BOSS	9	RETAINING CLIP
2	PUSH BUTTON VALVE BODY	10	CIRCLIP
3	RETAINING NUT	11	PUSH ROD 'O'RING
4	PUSH ROD	12	COLLAR 'O'RINGS
5	SHUT OFF VALVE	13	SHUT OFF VALVE 'O'RING
6	SPACER	14	BLIND RETAINING NUT
7	TANK BOSS 'O'RING	15	BLIND NIPPLE BODY
8	SHUT OFF VALVE SPRING		

**Figure 11**  
 Gauge Column Parts Diagram.





## Installation, operating and maintenance Instructions for Seeflex Gauge

Seetru Limited  
Albion Docksides Works  
Bristol, BS1 6UT, UK

Phone +44 (0) 117 927 9204  
Fax +44 (0) 117 929 8193  
Email enquiries@seetru.com

### EMERGENCY INSTRUCTIONS

No special emergency instructions apply to this type of gauge. Due to its design the volume of liquid in the gauge is isolated from the tank content and remains so unless a reading is actually being taken.

If the gauge is broken the small amount of liquid in the gauge glass will be lost, but the tank will remain sealed off.

### OPERATING INSTRUCTIONS TO READ LEVEL IN TANK

1. Depress the top valve, if fitted, and hold open
2. Depress the bottom valve and hold open. The level inside the tank should now register in the gauge glass.
3. When the liquid level settles release the valves to seal off the gauge from tank.

Note: The level shown in the sight tube will remain at this point. When a new reading is required repeat the above operations.

Note: If hydraulic actuator is fitted

1. Depress plunger knob/lever on actuator, which will open both valves simultaneously. Hold knob/lever until liquid level settles in the gauge.
2. Release knob/lever to seal off gauge from tank.

It should be noted that on gauges fitted with valves in top and bottom connections, the tank level shown may be incorrect if the bottom valve alone is operated. This is due to the trapping of air between the liquid and the upper valve. This would not occur in gauges fitted with a blind nipple assembly in the upper connection, as with this connection the top of the sight tube is always open to the tank.





**Installation, operating and maintenance**  
**Instructions for**  
**Seeflex Gauge**

Seetru Limited  
 Albion Docks Works  
 Bristol, BS1 6UT, UK

Phone +44 (0) 117 927 9204  
 Fax +44 (0) 117 929 8193  
 Email enquiries@seetru.com

OPERATING FAULTS

Faults	Probable Cause	Rectification	Maintenance Paragraph
Gauge not filling	Empty Tank	Fill	
	Obstruction in gauge	Clear	A
	Obstruction in body	Clear	E
Filling to incorrect level	Incorrect use of gauge	See operation instructions	
Broken sight glass	Misuse	Replace glass	B
	Misalignment	Replace glass - check tank face is flat	
Main valve not sealing	O' Ring damaged	Replace	E
	Broken spring	Replace	E

Leaks from:-

Collar Seal	Loose nut	Tighten	A
	O'Ring damage	Replace	A
Sight glass / gasket	Loose front bezel	Tighten bolts in sequence	B
	Damaged gaskets	Replace	B
Tank boss	O'Ring damaged	Replace	D
Push rod	O'Ring damaged	Replace	C





## HYDRAULIC ACTUATION - SINGLE GAUGE SYSTEM

### INSTALLATION AND OPERATION

(See Figure 5 & Figure 12)

The diagram, Fig 12, shows the plastic push button fitted to the lower Valve, however the gauge may be specified with the push button at either end. When mounting the gauge to the tank ensure that the fusible vent screw boss on each hydraulic head is pointing upwards.

Should the temperature surrounding the gauge exceed 147°F the fusible vent screws will melt. This renders the hydraulic system ineffective and hence prevents the isolating valves being opened due to thermal expansion of the hydraulic oil.

#### Gauges up to 3800 centers

These gauges will be packed complete with valves and hydraulic actuator system in position. The system will be charged with hydraulic fluid checked and be ready for use before it is despatched. To fit the gauge;

1. Remove the tank bosses from the gauge valves and weld them to the tank. For full details see Installation instructions on page 9.
2. Remove the cotter pins, which hold the upper, and lower hydraulic bodies to the gauge valve bodies.
3. Slide the upper and lower hydraulic bodies complete with the 1/8" O/D pipe from the valve bodies.
4. Remove the retaining nuts from valve bodies.
5. Slide the valves out of the gauge column collars.
6. Screw the valves into the tank bosses.
7. Refit the gauge column onto the valve bodies.
8. Refit the retaining nuts onto the valve bodies and tighten.
9. Refit the upper and lower hydraulic bodies onto the valve bodies. The 1/8" O/D pipe must be fitted on the left-hand side behind the back channel of the gauge column. Note, the fusible vent screw boss on each hydraulic body must face upwards.
10. Refit the cotter pins into the upper and lower hydraulic bodies, fit nuts to cotter pins and tighten.
11. To operate the gauge fully depress the black plastic plunger on the hydraulic body and hold until the level of the fluid in the gauge stabilises. Release the knob and take the tank level reading. The gauge is now isolated from the tank contents.

#### Gauges over 3800 centers (see also 'Gauges over 3.8m in length' on page 10)

These gauges will have the gauge column split for packing. The hydraulic system will be supplied complete, charged with hydraulic fluid checked and ready for use, but the pipe will be coiled i.e. not fitted to the gauge column. To fit the gauge to the tank, follow instructions 1,4,5,6,7 and 8 for gauges up to 3800 centres as above. Join the two halves of the gauge column together before attempting instruction 7.

Complete the installation by following the instructions below.

9. Straighten the coiled 1/8" O/D pipe and fit the upper and lower hydraulic bodies onto the valve bodies. The pipe must be fitted on the left-hand side behind the back channel of the gauge column. Note, the fusible vent screw boss on each hydraulic body must face upwards.
10. Fit the cotter pins into the upper and lower hydraulic bodies, fit nuts to cotter pins and tighten.
11. To operate the gauge fully depress the black plastic plunger on the hydraulic body and hold until the level of the fluid in the gauge stabilises. Release the knob and take the tank level reading. The gauge is now isolated from the tank contents.

## **INSTRUCTIONS FOR FILLING AND REMOVING AIR FROM THE HYDRAULIC SYSTEM**

The Hydraulic system is supplied by Seetru, filled and ready for use. These instructions are required only when the hydraulic system has been drained of fluid. See also **Figure 12**.

1. Assemble the rubber adaptor onto the syringe body
2. Remove the plunger from the syringe body
3. Remove the fusible vent screws from both the upper and lower hydraulic bodies.
4. Inset the syringe into the lower hydraulic body fusible vent screw hole.
5. Pour at least 30ml of hydraulic oil into the syringe and replace the plunger. Use the oil supplied with the filling kit or hydraulic oil type S.A.E. 70R3 or S.A.E. J1703B
6. Depress the plunger in the syringe until hydraulic fluid reaches the top of the fusible vent screw boss in the upper hydraulic body
7. Replace the fusible vent screw in the upper hydraulic body and tighten
8. Push in the lower hydraulic body plunger at least 3mm and hold in whilst fitting the check pin into the 1.0mm Dia. hole in the left-hand side of the lower hydraulic body. Release pressure on the plunger and allow it to move back against the check pin. This operation prevents the gauge being opened due to thermal expansion of the hydraulic oil.
9. Remove the syringe. Refit the fusible vent screw in the lower hydraulic body and tighten.
10. Make sure both fusible vent screws are tightened and not leaking.
11. Remove the check pin.
12. To operate the gauge fully depress the black plastic knob on the hydraulic body and hold until the level of the fluid in the gauge stabilises. Release the knob and take the tank level reading. The gauge is now isolated from the tank contents.

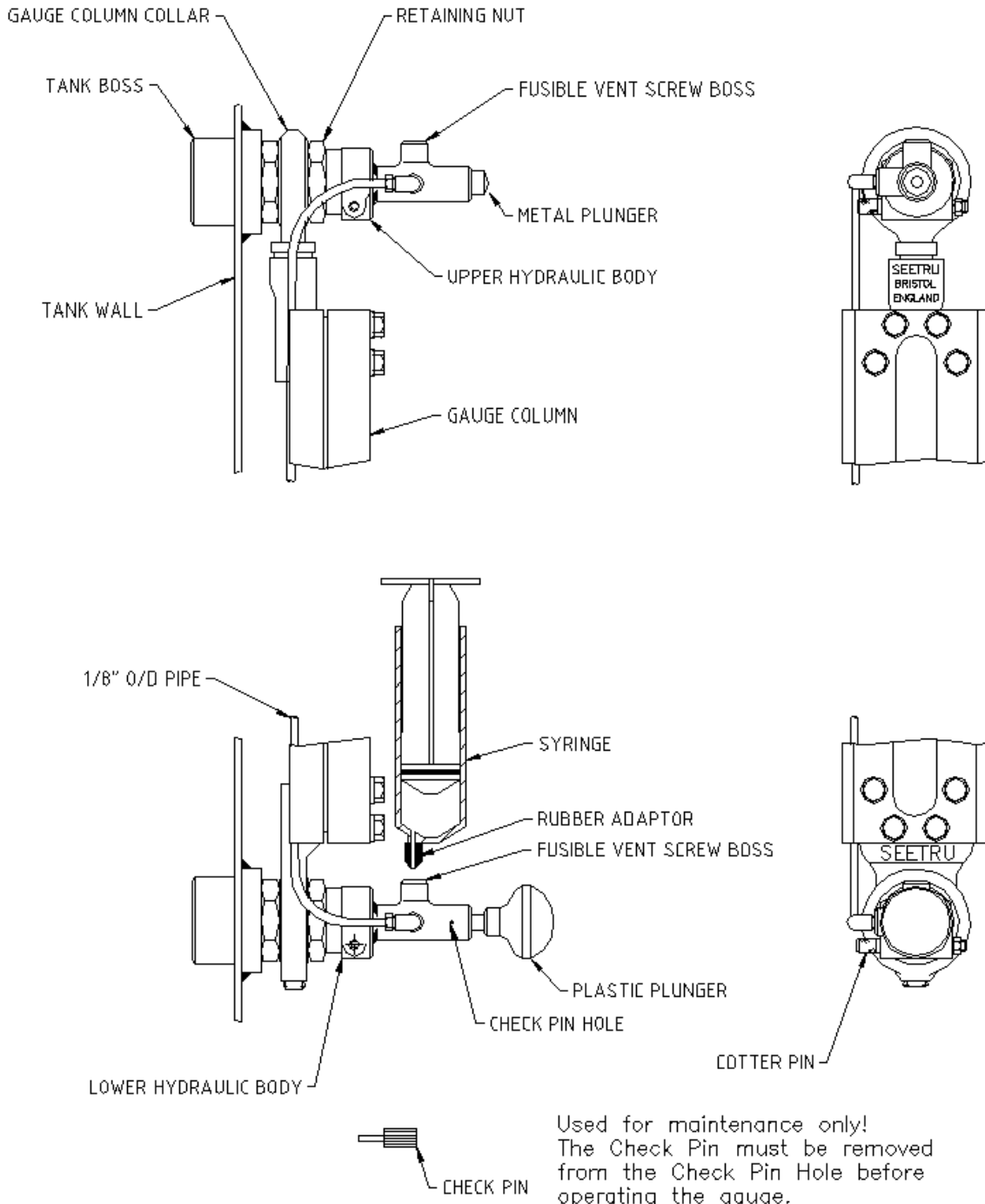
**If the valves do not operate correctly repeat the whole operation.**

If air enters the hydraulic system, the gauge valves may not open fully. This could result in a delay in obtaining a true reading of the liquid level in the tank i.e. the fluid will be restricted when flowing into the gauge. If this occurs carry the instructions above except item 6 which should be replaced with the following.

6. Insert a short length of clean flexible hose into the top fusible vent screw hole; insert the other end of the hose into a clear jar containing hydraulic oil type S.A.E. 70R3 or S.A.E. J1703B. Depress the plunger in the syringe, hydraulic oil will flow into the clear jar, continue until no air bubbles are present in the hydraulic oil leaving the gauge.

**Installation, operating and maintenance**  
**Instructions for**  
**Seeflex Gauge**

**Figure 12.**  
Hydraulic Actuation Single Gauge System – filling instructions.





## Installation, operating and maintenance Instructions for Seeflex Gauge

Seetru Limited  
Albion Dockside Works  
Bristol, BS1 6UT, UK

Phone +44 (0) 117 927 9204  
Fax +44 (0) 117 929 8193  
Email enquiries@seetru.com

### HYDRAULIC ACTUATION - MULTI-GAUGE SYSTEM

#### GENERAL DESCRIPTION.

(See Figures 6, 13, 14 & 15)

Seetru hydraulic actuation systems are made to measure and should be installed as received. Each hydraulic actuator head pump unit can operate up to four Seetru Marine push button valves simultaneously. For installations incorporating more than four actuator heads, two or more pump units are necessary. These can be grouped conveniently so that the handles can be operated simultaneously. The pump unit can be placed in any convenient position, either on the wall of the vessel or remote from it within maximum lengths of copper tube runs specified below.

Number of Actuator Heads	Maximum Length of pipe in meters
1	60m
2	30m
3	20m
4	15m

#### INSTALLATION

1. The push button valves in the gauge should be free and working properly.
2. The actuator head must be positioned with the vent screw boss uppermost, squarely and securely fastened to the gauge valve by the cotter pin provided.
3. The actuator head override push buttons should be "out".
4. The actuator pump vent plug should be uppermost, and the unit securely fastened to a rigid structure.
5. All units to be piped together with half hard copper tube installed free of kinks and sharp bends. All connections should be properly sealed.
6. Hydraulic oil is supplied with the filling kit. Alternatively use hydraulic oil type S.A.E. 70R3 or S.A.E. J1703B

#### FILLING

Before filling commences, check that the gauge has been correctly installed.

1. Remove all fusible vent screws.
2. Screw or push in filler in top actuator head vent screw boss.
3. Fill filler reservoir with hydraulic oil. Allow the system to fill by gravity, keep the oil, level, in the reservoir filler, at all times. As discharge is observed from lower vent screw boss, wait until bubbles cease and all air is vented from the pipe and actuator pump equipment. Refit vent screws.
4. Before removing filler, observe level in reservoir and work actuator pump. There will be considerable agitation in the reservoir.
5. Remove filler and fill top vent screw boss with hydraulic fluid. Fit top vent screw,

Work actuator pump handle. Resistance should be felt. The isolating valves will open; gauge column will fill if tank contains liquid. If tank contains heavy viscous fluid, actuator pump handle must be held in whilst gauge column fills slowly.

If no resistance is felt and gauge column does not fill (Isolating valves not opening) the system will still contain air. Proceed as follows.



## VENTING

1. Remove vent screw on top actuator head.
2. Fit filler and recharge reservoir.
3. Operate actuator pump handle and observe discharge of air bubbles if any. When clear, remove filler, fill vent screw boss, and refit vent screw.

Work actuator pump handle. Resistance should be felt. The Isolating valves will open; gauge column will fill if tank contains liquid. If tank contains heavy viscous fluid, actuator pump handle must be held in whilst gauge column fills slowly. If no resistance is felt and gauge column does not fill (Isolating valves not opening) the system will still contain air. Proceed as follows.

4. Remove vent screw on actuator pump.
5. Fit filler on actuator pump and recharge reservoir. Operate actuator pump handle and observe discharge of air bubbles if any. When clear, remove filler, fill vent screw boss and refit vent screw.

Work actuator pump handle. Resistance should be felt. Isolating valves will open; gauge column will fill if tank contains liquid. If tank contains heavy viscous fluid actuator pump handle must be held in whilst gauge column fills slowly. If no resistance is felt and gauge column does not fill (Isolating valves not opening) the system will still contain air.

Proceed as follows.

6. Remove vent plug on lower actuator head. Fit filler on lower actuator head and recharge reservoir. Operate actuator pump handle and observe discharge of air bubbles if any, when clear, remove filler, fill vent screw boss and refit vent screw,

Work actuator pump handle. Resistance should be felt. Isolating valves will open; gauge column will fill if tank contains liquid. If tank contains heavy viscous fluid, actuator pump handle must be held in whilst gauge column fills slowly. If no resistance is felt and gauge column does not fill (Isolating valves not opening) the system will still contain air. Check all pipe joints for leaks and repeat the whole venting procedure.

If resistance is felt when working actuator pump, then system is now completely purged of air and all vent screws are tight.

## SETTING

For setting of a multi-gauge Hydraulic Actuation system, see **Figure 13**



# Installation, operating and maintenance Instructions for Seeflex Gauge

Seetru Limited  
Albion Dockside Works  
Bristol, BS1 6UT, UK

Phone +44 (0) 117 927 9204  
Fax +44 (0) 117 929 8193  
Email enquiries@seetru.com

## OPERATION

To operate this system, depress actuator pump handle and hold down lever. If isolating valves do not open see Fault Finding section below. Actuator heads are fitted with a push button for manual emergency operation. When used, the hydraulic system is overridden.

## MAINTENANCE

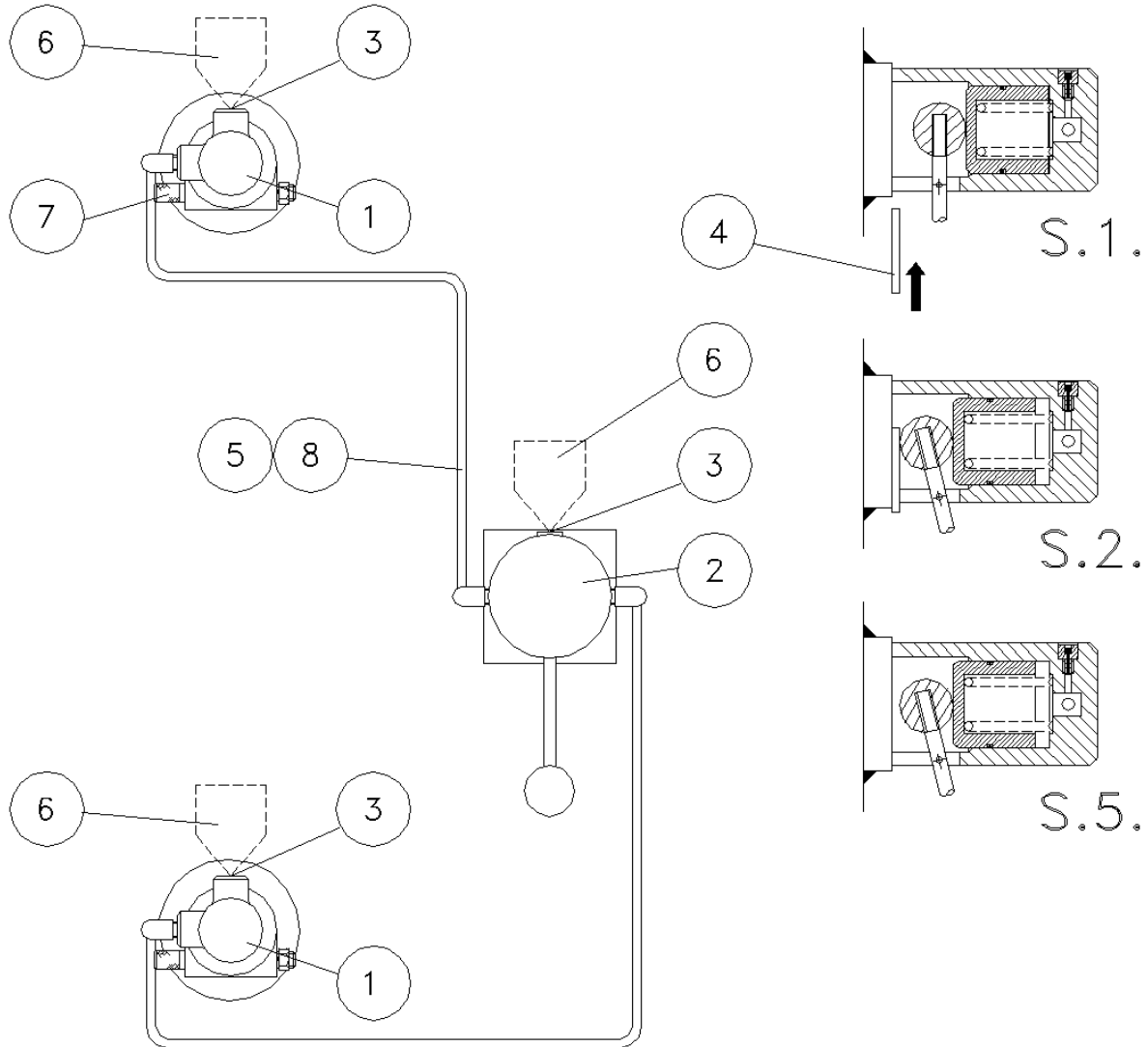
The vent screw boss's have fusible alloy inserts (vent screws). If fluid loss is experienced following a fire in the vicinity of the system fit new vent screws and refill system working through sections Filling, Venting and Setting. No standard maintenance is required. If system is not working properly, or has been dismantled and disconnected, work through Filling, Venting and Setting instructions.

## FAULT FINDING

<b>Fault</b>	<b>Cause</b>	<b>Cure</b>
No level in the gauge glass	Empty tank	Fill
Gauge valves not opening	Loose actuation head	See installation section
	Air in system	Work through Filling, Venting & Setting sections
	Fluid Loss	See Maintenance & Filling, Venting & Setting sections
	Broken Pipe	See Filling, Venting & Setting sections.
	Leaking connection	Tighten. See Installation section.

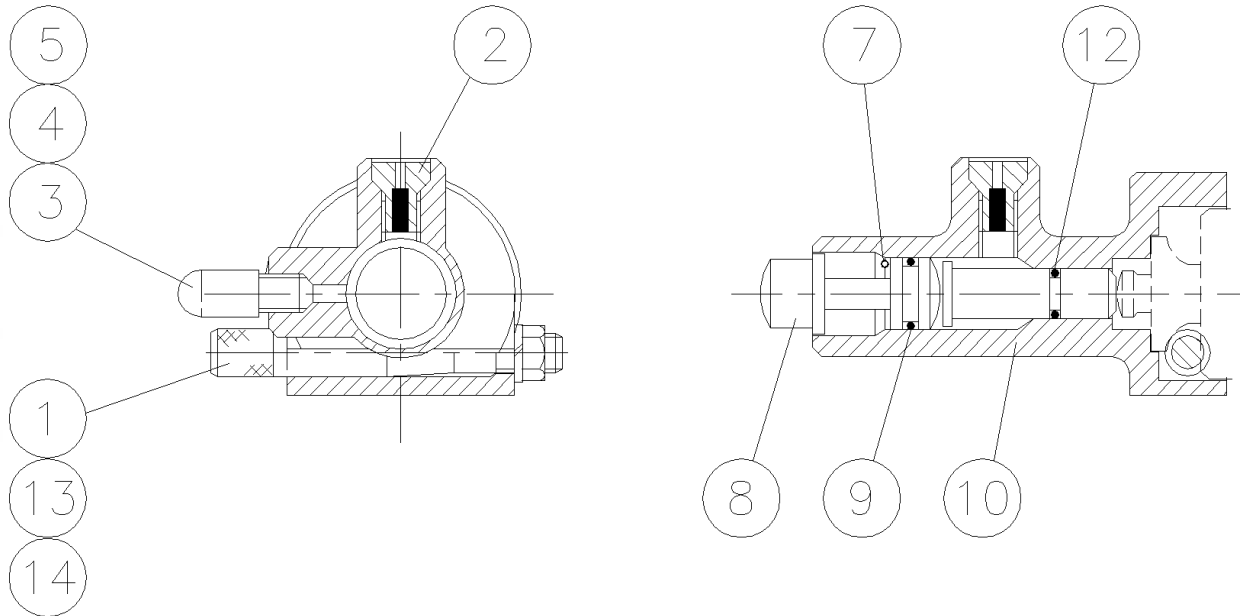


**Figure 13.**  
Setting Information



PARTS LIST	SETTING
ITEM	
1 Actuator Head	S.1. Depress actuator pump handle to open isolating valves. Hold open and hold setting gauge in position.
2 Actuator Pump	S.2. Allow actuator to return until gripping the setting gauge.
3 Fusible Vent Screw	S.3. Ease back vent plug actuator. Fluid will vent off as gauge valves close.
4 Setting Gauge	S.4. Tighten fusible vent screw.
5 Tube	S.5. Remove setting gauge.
6 Filler	
7 Cotter Pin	
8 Fluid	

**Figure 14**  
Actuator Head

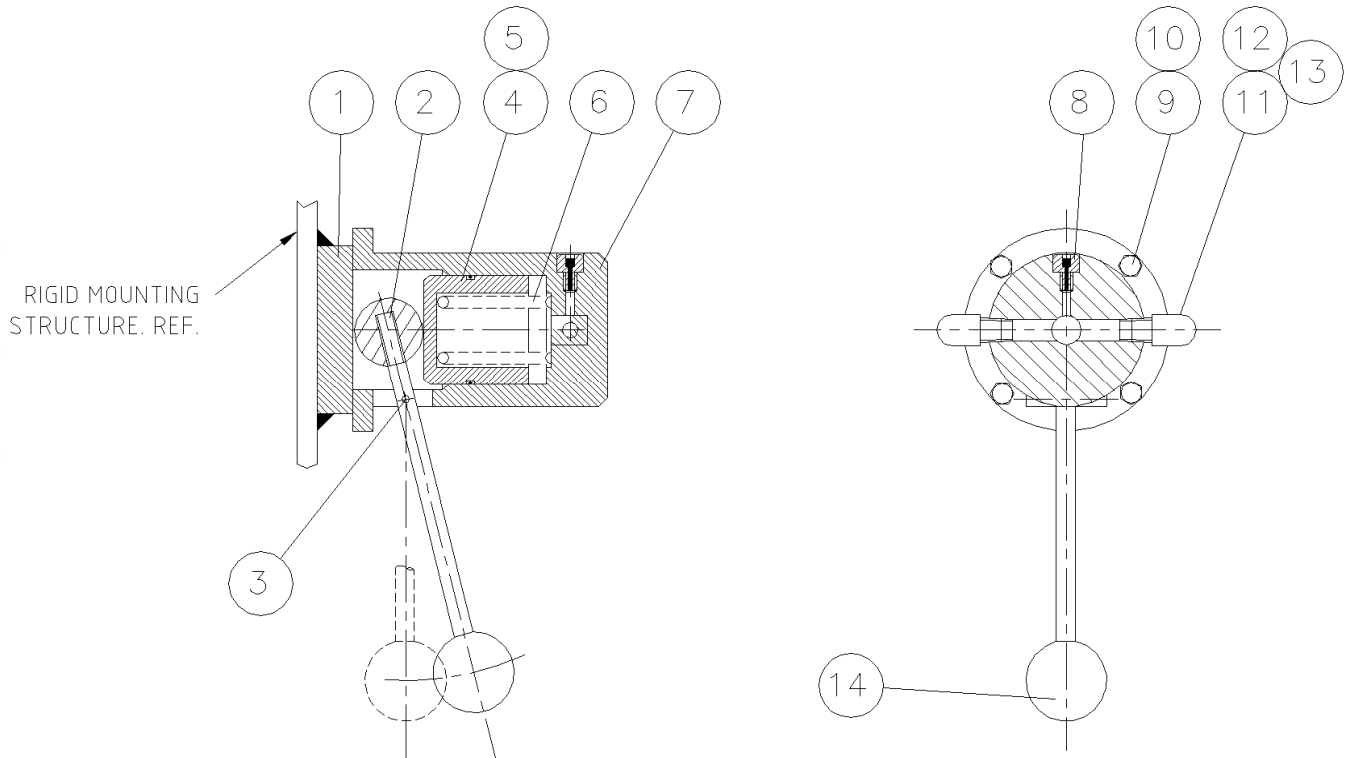


ITEM No.	DESCRIPTION
1	COTTER PIN
2	FUSIBLE VENT SCREW
3	ELBOW
4	OLIVE, TUBE FITTING
5	TUBE NUT, TUBE FITTING
6	
7	LOCKING PIN

ITEM No.	DESCRIPTION
8	PUSH BUTTON
9	O'RING
10	BODY
11	PLUNGER
12	O'RING
13	NUT
14	WASHER



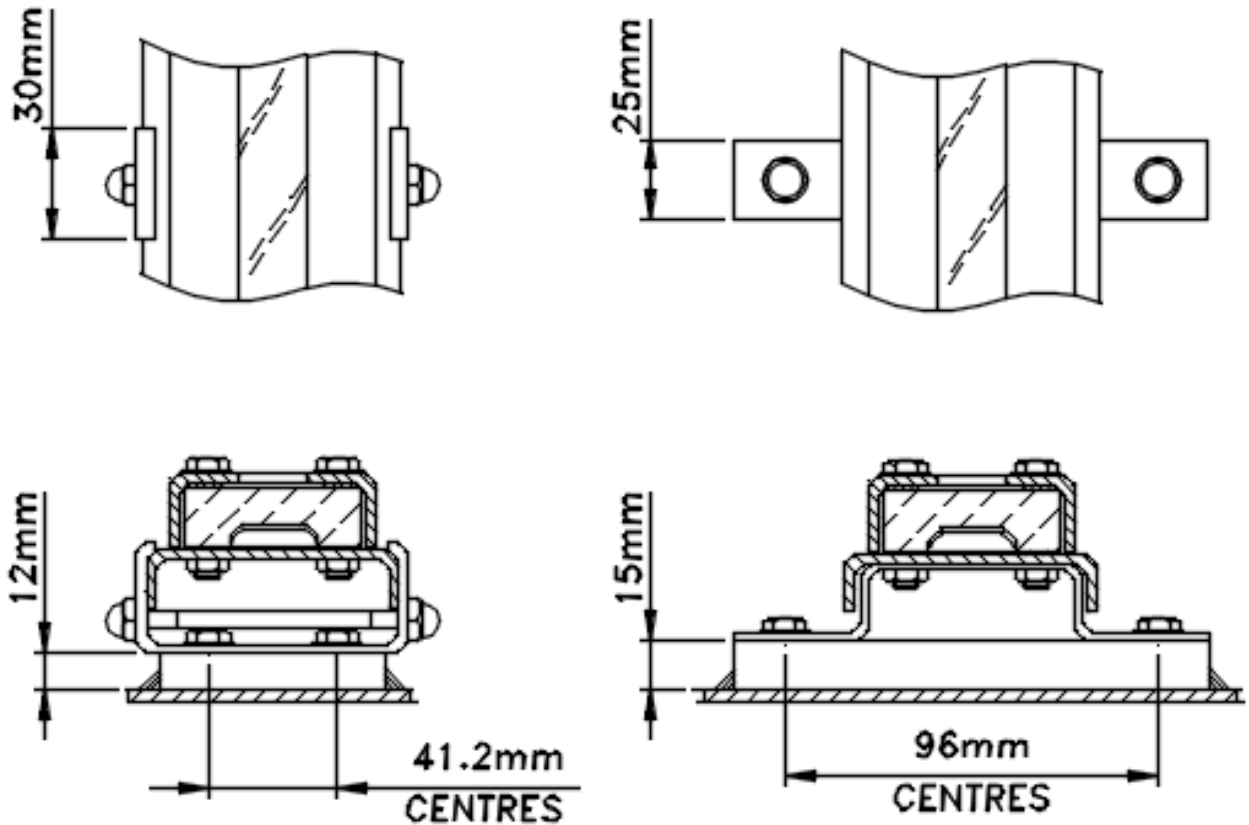
**Figure 15**  
 Actuator Pump



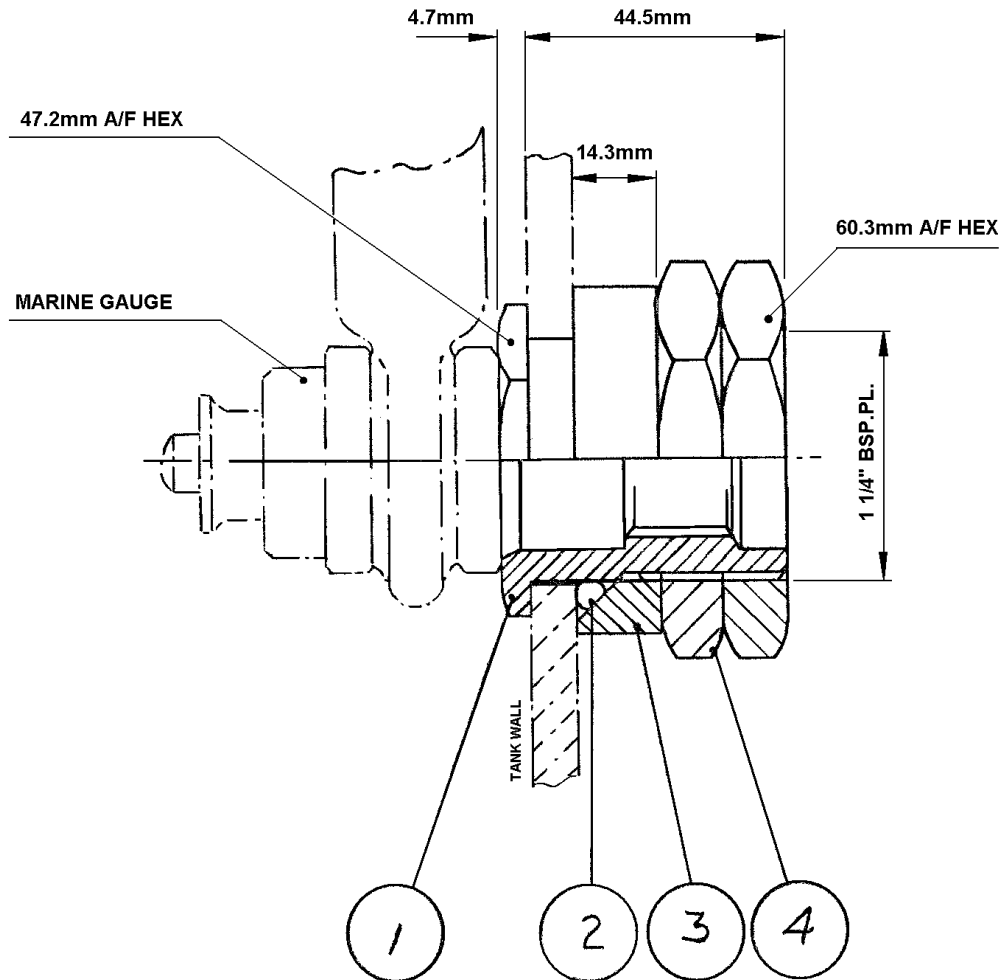
ITEM No.	DESCRIPTION
1	TANK PAD
2	HANDLE ASSEMBLY
3	PIVOT PIN
4	O'RING
5	PISTON
6	SPRING
7	BODY

ITEM No.	DESCRIPTION
8	FUSIBLE VENT SCREW
9	HEX SCREW
10	SPRING WASHER
11	ELBOW, TUBE FITTING
12	OLIVE, TUBE FITTING
13	NUT, TUBE FITTING
14	PLASTIC KNOB

**Figure 16**  
 Support dimensions



**Figure 17**  
Alternative Tank Boss fitting – non weld type



The Tank Boss is only suitable for use with tanks of wall thickness from 1.58mm (1/16") to 7.9mm (5/16"). Hole diameter of 42.0mm is required in the tank wall.

ITEM No.	No. OFF	NAME
1	1	TANK BOSS
2	1	O'RING
3	1	PRESSURE RING
4	2	LOCK NUT